

EXPERIENCE MOBILITY

ELECTROMOBILITY DRIVE COMPONENTS.

BATTERY. FUEL CELL. EDU.

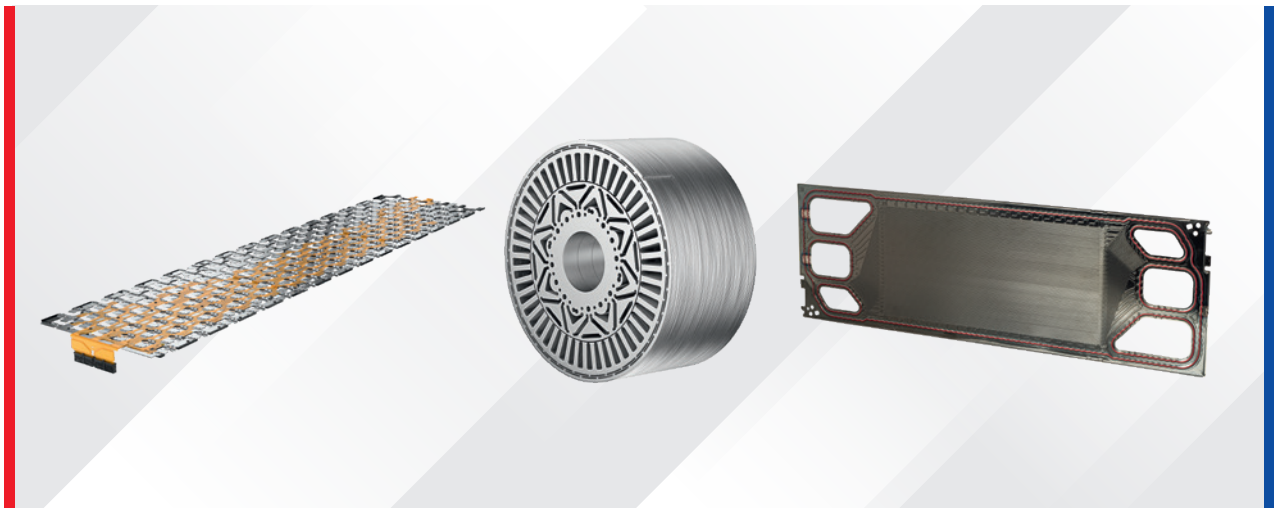

SYSTEM PARTNER. PROBLEM SOLVER. PIONEER.

SHAPING THE FUTURE. WITH ELRINGKLINGER.

For us, system expertise means being a pioneer, creating freedom and reaching goals faster. With our portfolio, we offer groundbreaking solutions for all vehicles, whether traditional, hybrid or pure electric.

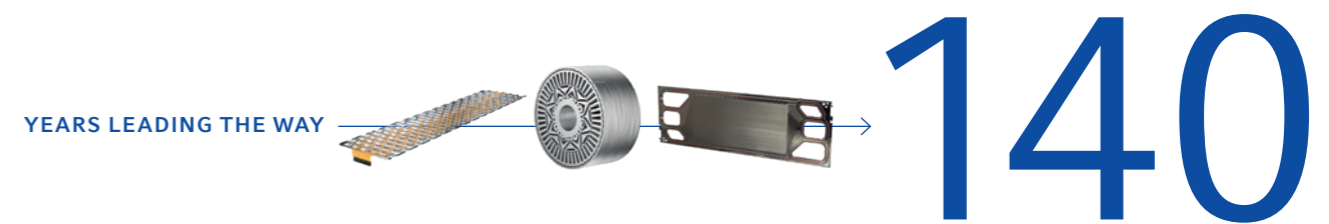

Nothing can replace experience combined with innovative spirit. ElringKlinger has plenty of both. In 1879, Paul Lechler founded a trading company for technical products, which would later become ElringKlinger AG. Today, we are a global player offering future-proof solutions for all drive types in all product areas. We also demonstrate our strengths in other industrial sectors. Proximity to the customer, developing visions and overcoming challenges are some of our key strengths. For over 140 years.



Alternative drive technologies, lightweight engineering concepts, new forms of mobility, sustainability and climate protection: The transformation process in the automotive industry is in full swing. The agenda for the future is clear. We are also working every day to play our part and push the limits of what is possible. We are focusing on four strategic fields: Electromobility, lightweight construction for all drive types, traditional mobility and non-automotive. Together with our customers, we are already finding answers to the questions of the future. And successfully driving forward innovations.



For our customers, we are a strong and reliable development partner and series supplier with unique expertise. We are a pioneer and companion. From the idea to the finished product. Whether electromobility, lightweight solutions, sealing and shielding technology or tool technology – ElringKlinger impresses with the highest quality, reliability and performance. Around 9,500 employees are committed to achieving this at more than 40 sites worldwide.

COMPONENTS FOR THE ELECTRIC DRIVE. EXPERTISE FOR THE TRANSFORMATION.

Transformation of the automotive industry is moving faster all the time. ElringKlinger has been working on alternative drive concepts for more than 20 years already and was quick to position itself as a specialist in electric mobility. The basis for this is our unique material expertise, our extensive know-how in the fields of development, high-precision metal processing and coating processes, and our unbeatable 140 years of experience. ElringKlinger offers product solutions suitable for series production in battery and fuel cell technology and electric drive units. All of them are available in extremely flexible customized designs or based on standardized products and systems, as modular solutions or individual components.

Moving people is what moves us:
we want to develop mobility in all its facets and make it as resource-efficient, environmentally friendly, safe, convenient, and efficient as possible.



FUTURE-PROOF SOLUTIONS – AS SERIES

BATTERY COMPONENTS.

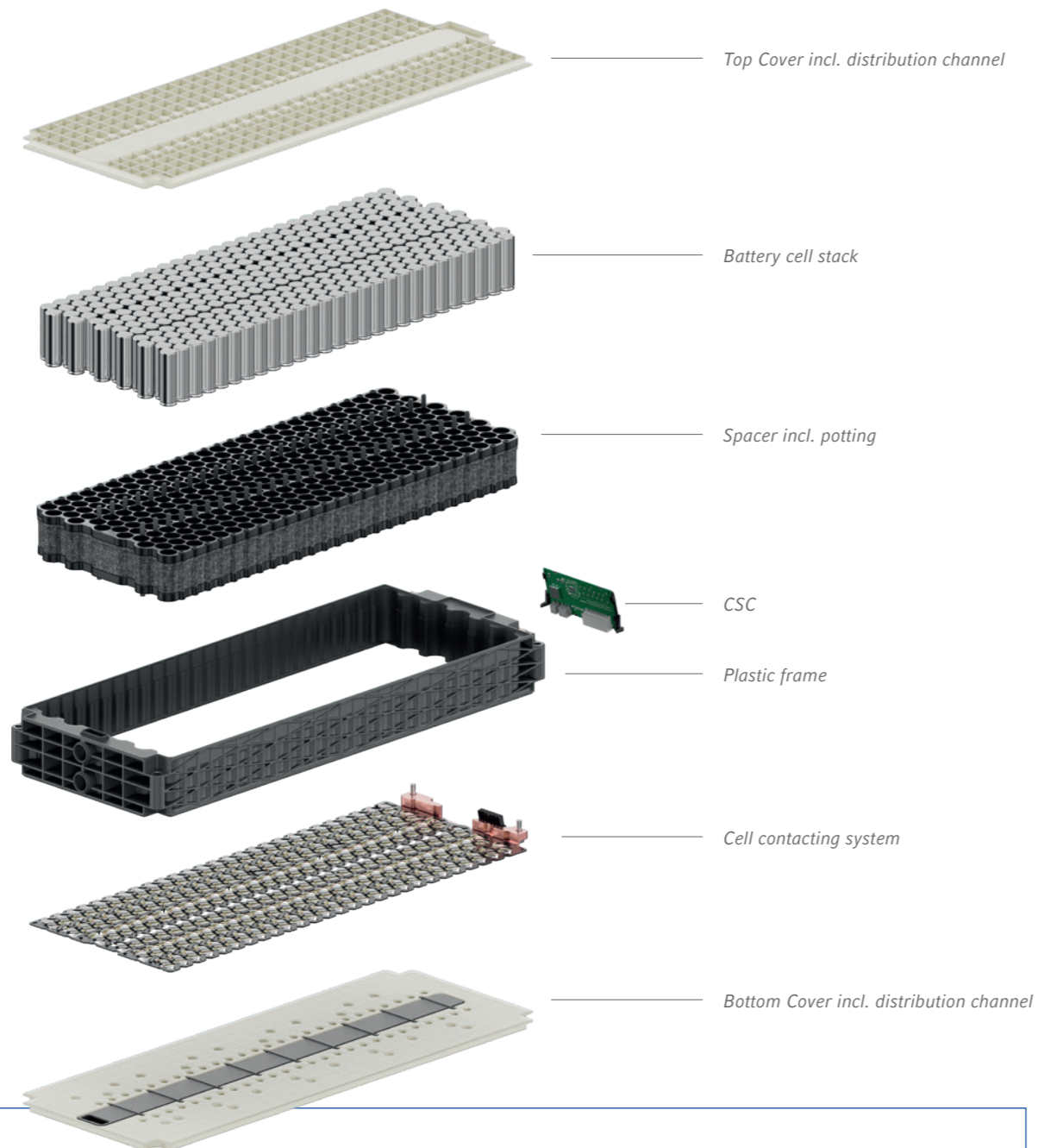

With our battery components, we are ideally placed for alternative drive technologies. The major advantage for our customers: ElringKlinger offers development and prototype construction to testing and series production from a single source. We have been a series supplier in battery technology for more than 10 years.

Cell contacting system for cylindrical lithium-ion cells with flexible printed circuit board as signal carrier.

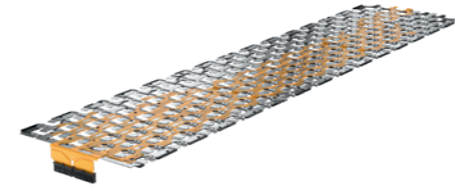

CELL CONTACTING SYSTEMS

- + specifically coordinated
- + mounted directly on the cell unit in various expansion stages and welded
- + plastic carrier frame holds cell connectors, ensuring that they can be installed in all tolerance positions
- + integrated voltage and temperature sensors
- + monitoring electronics (CSC) can also be integrated
- + automotive plug systems or screw connectors

The safety elements for overpressure, excess temperature and current ensure an outstanding level of safety even at cell level.



CELL HOUSINGS AND COVERS

- + cylindrical, prismatic, pouch
- + exceptionally reliable even in large volumes
- + reduced number of components and complexity
- + reduced use of materials
- + lower CO₂ footprint by up to 40 percent

The integrated emergency degassing function ensures rapid, controlled pressure equalization in the event of battery cell outgassing.



PRESSURE EQUALIZING UNITS

- + compensates for pressure differences in the storage housing (e.g. when driving up and down mountains, with temperature differences, for air transport in aircraft cargo holds without pressure equalization)
- + with integrated safety function for critical excess pressure

Immersion-cooled battery system from ElringKlinger: lightweight battery housing and plastic modules.



PLASTIC BATTERY HOUSING AND MODULES

- + weight and cost reduction
- + reduced installation work
- + integrated functions, reduced number of components
- + optimized NVH properties
- + low thermal conductivity
- + excellent electrical insulation

In-house development by ElringKlinger:
ElroForm™ battery housing.



ELROFORM™ METALLIC ASSEMBLIES/FORMED PARTS

- + e.g. battery housing, module housing
- + carrier layer provides structural strength and rigidity
- + weight and cost reduction
- + functions can be integrated
- + optimized NVH properties

ElroForm™ battery cover: safe, light,
durable and economical.



ELROFORM™ AND ELROSHIELD™ EV METALLIC BATTERY COVERS

- + e.g. for module separators
- + one or more parts
- + functions can be integrated
- + for high requirements for crash safety, thermal conditions (up to 1,100°C), particle coating and acoustics

ElroShield™ EV: multi-layer, metallic
insulation solution for battery systems.



THERMAL PROPAGATION MEASURES (COVERS)

- + ElroSafe™ (lightweight, continuous fiber-reinforced thermoplastic composite material)
- + ElroShield™ EV (metallic, multi-layer)
- + optimum protection against burn through and particle coating
- + controlled gas feed during thermal propagation events

ElroSafe™: thermoplastic composite
insulation solution for battery systems.

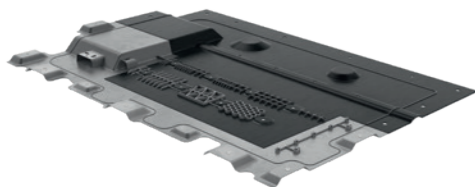

Metal-elastomer gasket in puzzle design:
individual parts are quickly and easily
slotted into one another, pre-positioning
using elastomer pins.

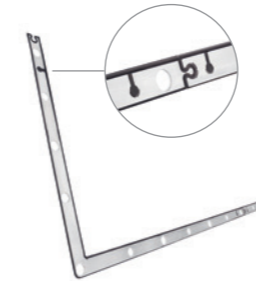

ELASTOMER/METAL ELASTOMER SEALING SYSTEMS

- + e.g. for large flanges (battery housing)
- + for highly stressed components
- + adaptable to any geometries
- + fast installation, low space requirements
- + totally safe, even with low sealing pressures
- + long-term corrosion protection
- + double sealing lip system possible
- + elastomer materials developed in-house by ElringKlinger

MetalSeal™ for battery applications,
e.g. for sealing HV connectors with
additional EMC function.



METALOSEAL™ METAL BEAD GASKETS

- + functional coatings, e.g. conductive coating for EMC shielding
- + installed in the main line of force
- + positioning plates and retaining clips for quick and reliable installation, vertical and upside down
- + high media, temperature and pressure resistance

TopSeal™: deep-drawn cover with gasket
in single component.



TOPSEAL™ DEEP-DRAWN COVERS

- + e.g. battery module cover
- + topographic support of the integrated gasket using embossed stoppers
- + improved corrosion resistance
- + with functional integration, e.g. screws, ventilation elements
- + best possible shielding against electromagnetic radiation

Pressure equalizing unit with PTFE
membrane: easy press-in and reliable venting
with customized design solutions.



MADE OF HIGH-PERFORMANCE PLASTICS

- + e.g. insulation elements, cell cover and PTFE membrane for pressure equalizing units
- + chemical resistance to aggressive media
- + very reliable at high temperatures
- + reliable ventilation with customized designs

DRIVING THE MOBILITY TRANSITION

COMPONENTS FOR PEM FUEL CELLS.



Our PEMFC components meet the highest of demands in terms of robustness, functionality, and performance. ElringKlinger has been actively involved in the field of fuel cells for around 20 years and launched its first series production project back in 2008.

Bipolar plates

TopSeal™
deep-drawn cover



Essential components for PEMFC stack modules: metallic bipolar plates from EKPO Fuel Cell Technologies, a joint venture between ElringKlinger and Plastic Omnium.

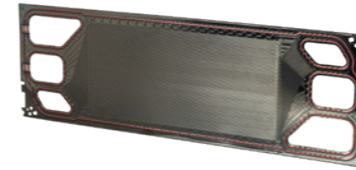

METALLIC BIPOLAR PLATES FROM EKPO

- + made of corrosion-resistant steels
- + compact design
- + cost-efficient processes and materials
- + various coating options
- + functional plate design right through to series production developed in conjunction with customers
- + optimum power density and cold start capability of PEMFC
- + production with high-precision progressive tools
- + fully automated, interlinked production process

Metal-elastomer gaskets ideal for automated stack assembly.

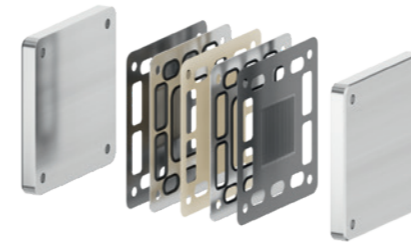

ELASTOMER/METAL ELASTOMER SEALING SYSTEMS

- + e.g. bipolar plates with integrated gaskets or sealing of individual cell levels
- + XL dimensions possible
- + for components in high-pressure applications
- + reliable sealing even with low sealing pressures
- + equalization of high component tolerances
- + three-dimensional shaping
- + reduction of screw force and number of screws
- + elastomer materials developed in-house by ElringKlinger

Functional bipolar plate with integrated sealing function.

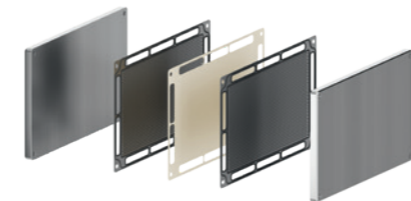

MetaloSeal™ gasket, design and material specifically tailored to fuel cell applications.

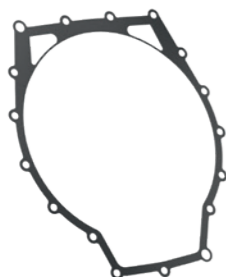

METALOSEAL™ METAL-BEAD GASKETS

- + e.g. compressor gaskets
- + thanks to numerous combination options for metals and elastomers, can be adapted precisely to the relevant requirements
- + functional coatings, e.g. conductive coating for EMC shielding
- + installed in the main line of force
- + positioning plates and retaining clips for quick and reliable installation, vertical and upside down
- + high media, temperature and pressure resistance

TopSeal™: deep-drawn cover with gasket in single component.

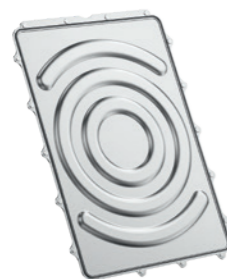

TOPSEAL™ DEEP-DRAWN COVERS

- + e.g. service cover, FCCU cover
- + topographic support of the integrated gasket using embossed stoppers
- + improved corrosion resistance
- + with functional integration, e.g. screws, ventilation elements
- + best possible shielding against electromagnetic radiation

ElroSeal™ SP rotary shaft seals: redefining the limits of what is possible.



MADE OF HIGH-PERFORMANCE PLASTICS

- + e. g. spring energized seals (EFN) for rods sealing in valves for hydrogen control
- + ElroSeal™ B/E/SP rotary shaft seals for sealing fast-rotating shafts against cooling media in electric chargers, blowers and compressors



GOOD TO KNOW

We want to create scope for our customers to achieve goals more quickly and further advance sustainable mobility. That's why we always have the entire system in mind and make targeted use of our know-how and innovative strength to realize optimal product solutions.

DRIVING FORCE FOR E-MOBILITY

COMPONENTS FOR ELECTRIC DRIVE UNITS.

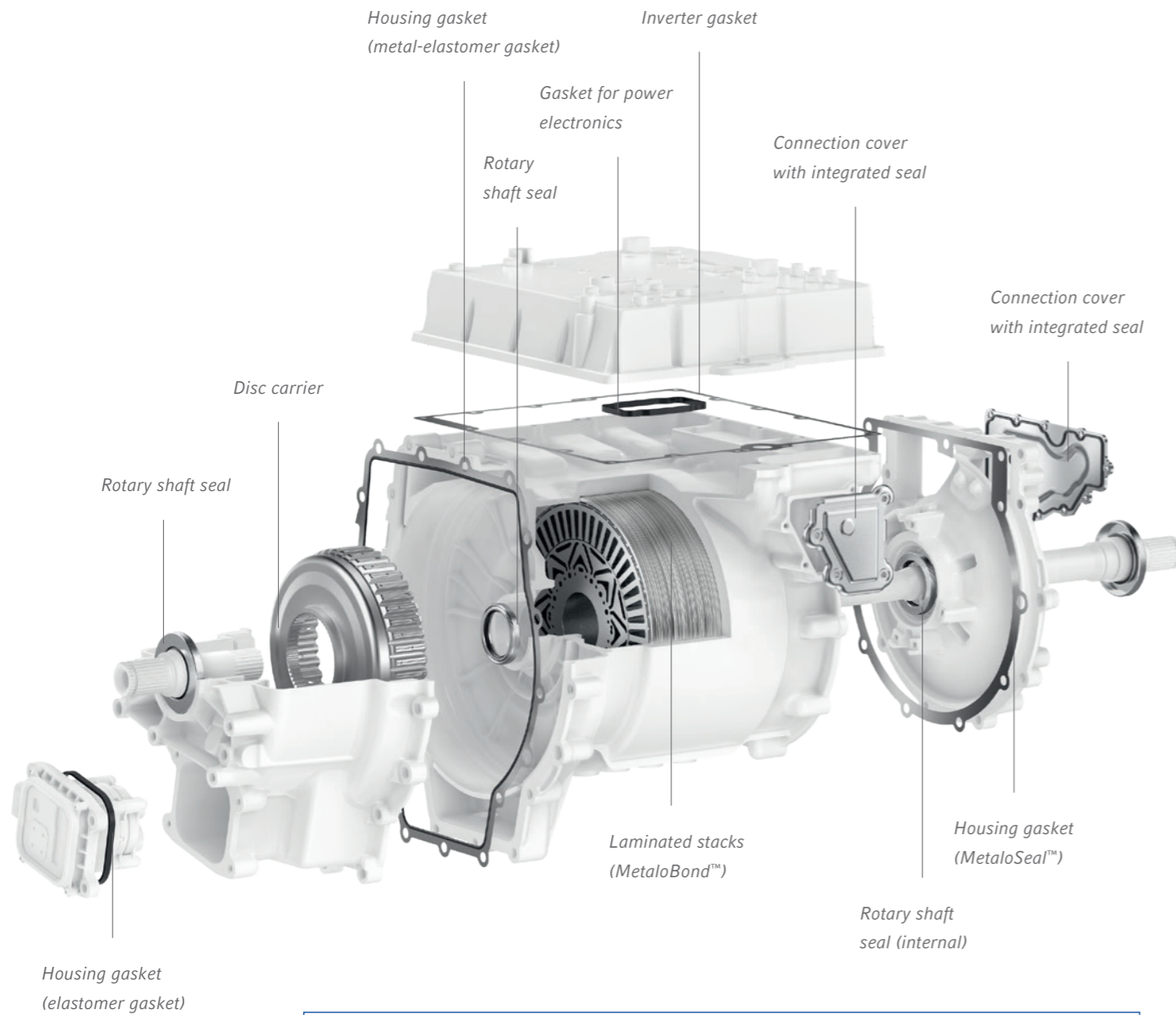

A wide range of ElringKlinger components relating to e-motors, transmissions and inverters can be used in an electric drive unit. The design and materials of all our product solutions are tailored precisely to the relevant requirements – for maximum design freedom and functional reliability.

MetaloBond™ rotor/stator laminated stacks: powerful and flexible.



METALOBOND™ ROTOR/STATOR LAMINATED STACKS

- + full bonding of the layers ensures optimum sealing function in order to implement directly cooled electric machine concepts
- + improved strength and NVH performance
- + thin sheets possible for even more efficient electric machine operation
- + in-house development of adhesive enables maximum flexibility in material selection
- + less pressing strokes required to achieve the stack height due to innovative manufacturing processes

Balancing disc with weight and cost-optimized design.



STAMPED BALANCING DISCS

- + stamped/formed part with weight and cost-optimized design
- + high precision production process ensures tight tolerances and eliminates secondary processes
- + maximum flexibility with regard to material selection
- + material thicknesses up to 10 mm possible

Planetary carriers for longer transmission service life.



PLANETARY CARRIERS

- + new method: planetary gears integrated into formed sheet metal part
- + weight and cost savings
- + high torques and speeds
- + longer service life of the gear wheels

Disc carriers for transmitting higher torques.

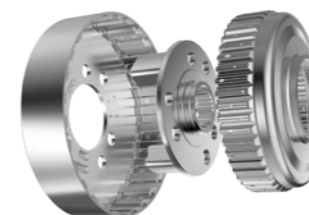

DISC CARRIERS

- + high strength for transmission of higher torques
- + maximum precision and functional reliability
- + weight savings of up to 50 percent compared to standard commercially available solutions

Differential housing with weight-optimized sheet metal design.



DIFFERENTIAL HOUSING

- + formed sheet metal design
- + significant weight reduction in applications with high torque

Engine mount made of glass-fiber reinforced thermoplastics.



ENGINE AND UNIT MOUNTS

- + made of glass-fiber reinforced thermoplastics
- + multifunctional
- + weight and cost reduction
- + improved NVH characteristics
- + low thermal conductivity
- + high dimensional accuracy
- + high process stability and repeatability

Plastic inverter housing with integrated EMC shielding.



PLASTIC MODULES

- + e.g. inverter housing, resolver cover, media distributor modules
- + with integrated EMC shielding
- + weight and cost reduction
- + functions can be integrated
- + optimized NVH properties
- + low thermal conductivity
- + high process stability and repeatability

ElroForm™ inverter cover: safe, lightweight, durable and economical.



ELROFORM™ METALLIC COVERS

- + e.g. for inverters, HV shielding and charging unit
- + ideally suited for replacing die-cast parts
- + one or more parts
- + functions can be integrated
- + for high crash safety requirements

Metal-elastomer stator housing gasket with split carrier.



ELASTOMER/METAL ELASTOMER SEALING SYSTEMS

- + e.g. inverter gaskets, stator housing gaskets, transmission housing gaskets
- + for highly stressed components
- + electrical conductivity for EMC requirements
- + elastomer materials developed in-house by ElringKlinger
- + reliable sealing even with low sealing pressures
- + sealing of T-joints
- + equalization of high component tolerances
- + three-dimensional shaping
- + reduction of screw force and number of screws

MetaloSeal™ stator housing gasket including sealing of integrated cooling channels.



METALOSEAL™ METAL-BEAD GASKETS

- + e.g. stator housing gaskets, transmission housing gaskets, inverter gaskets
- + thanks to numerous combination options for metals and elastomers, can be adapted precisely to the relevant requirements
- + functional coatings, e.g. conductive coating for EMC shielding
- + installed in direct line of force
- + positioning plates and retaining clips for quick and reliable installation, vertical and upside down
- + high media, temperature and pressure resistance

Functional integration and shielding: TopSeal™ cover with integrated gasket.



TOPSEAL™ DEEP-DRAWN COVERS

- + e.g. inverter cover, service cover, cover of electrical components and connection covers
- + topographic support of the integrated gasket using embossed stoppers
- + improved corrosion resistance
- + with functional integration, e.g. screws, ventilation elements
- + best possible shielding against electromagnetic radiation

ElroSeal™ EG rotary shaft seal: reliable sealing and discharge at maximum rotational speeds.



MADE OF HIGH-PERFORMANCE PLASTICS

- + ElroSeal™ B/E/EM/SD rotary shaft seals and piston rings for fast-rotating shafts
- + ElroSeal™ G/EG rotary shaft seals for bearing protection
- + venting elements for brush space
- + dynamic sealing at extreme rotational speeds, can also be combined with reliable discharge for component protection

BUNDLED KNOW-HOW

EXPERTISE IS OUR MIDDLE NAME.

Always questioning the tried and tested, refusing to settle for standards that have been achieved. This has always been a hallmark of ElringKlinger. This is where we apply our unique expertise in materials, engineering, processes, and manufacturing methods. In addition, we invest around five percent of Group turnover in research and development each year.

SYSTEM EXPERTISE GIVES US THE EDGE

Short development cycles, the complex interaction of all components, and exacting demands in terms of cost-effectiveness and sustainability make an integrated approach essential. This is an important factor in ElringKlinger's success, as everything from the initial concept to the finished product comes from a single source.

Our core competences include stamping, embossing, forming and coating metal, plastic injection molding, and the processing of high-performance plastics. We are also able to combine a large number of different components into a single assembly with high process reliability. Another core competence is tooling technology, as we design and manufacture a large proportion of the tools we use ourselves in our in-house tool shop.

For us, system expertise means being a pioneer, creating space for development, and achieving our goals more quickly.



GOOD TO KNOW

In addition to drive components, ElringKlinger offers further tailored product solutions for electric vehicles in the fields of thermal management, body & interior, chassis & braking system and underbody. Underbody protection is a particular focus here – we offer the right solution for every application: ElroForm™ (metallic, single or multi-part), ElroSafe™ (thermoplastic composite material), ElroShield™ (metal plus insulating material), ElroCoustic™ (noise damping), GMT (glass mat reinforced thermoplastics) and LWRT (low weight reinforced thermoplastics). Safe and reliable even under the toughest conditions.

ElringKlinger AG

Max-Eyth-Straße 2
72581 Dettingen/Erms
Germany
Phone +49 7123 724-0
E-mail info@elringklinger.com

www.elringklinger.com

The data provided here are the result of technological investigations. Such details are subject to change depending on the design of the system. We reserve the right to implement technical changes and improvements. The data are nonbinding and do not represent guaranteed characteristics. We accept no claims for compensation based on this information. We accept no liability for printing errors.